

Inserts

Face milling cutters

Square shoulder cutters

Slot cutters

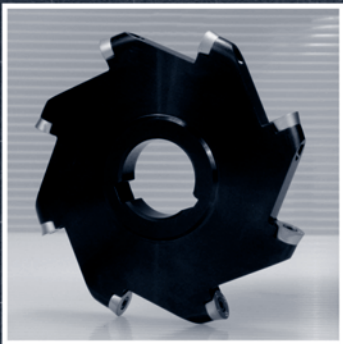
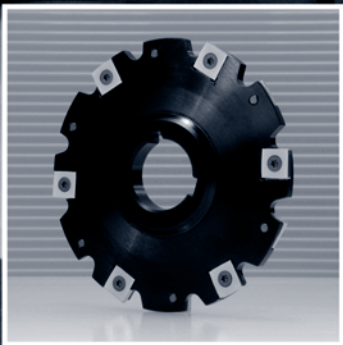

Slot cutters

Technical information	D.02
Contents-Applications	D.03
Code key	D.03
T-Slot cutters	D.04
Slot cutters	D.06
Cutting data	D.16

Slot cutters

Porcupine cutters

Specific applications
and sets

Profile milling

Solid carbide

Drills

Boring heads

Arbors and
adaptors

Inserts

Face milling
cuttersSquare shoulder
cutters

Slot cutters

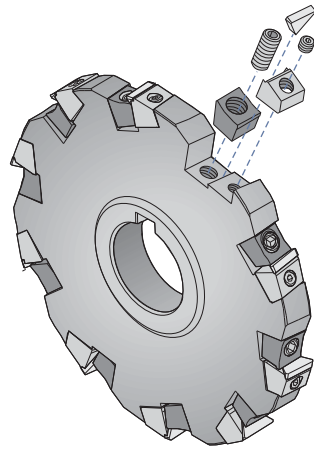

Wedge clamping

This classic positive insert clamping system allows the use of all models presenting this geometry, both with additional chipbreaker and sintered.

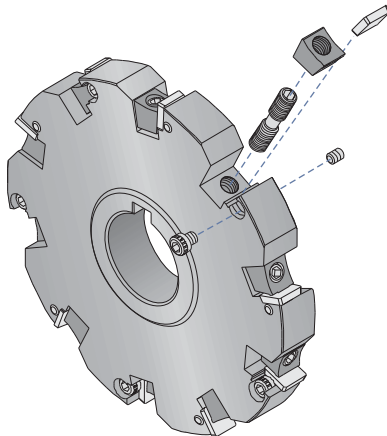

Wedge clamping

This classic positive insert clamping system allows the use of all models presenting this geometry, both with additional chipbreaker and sintered.

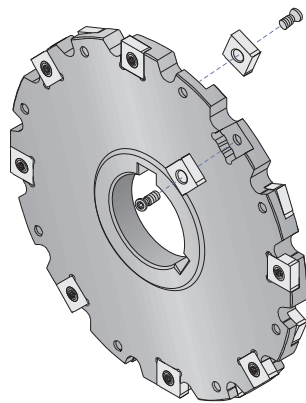

Screw clamping



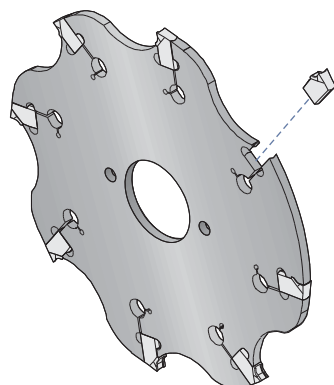



Since the advent of the Torx screw it has been possible to hold with complete safety positive inserts with centre hole. Our range covers all the screw fixing permutations.

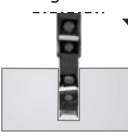

Spring action

The inserts are retained by a clamping/spring action into a fixed insert seat.

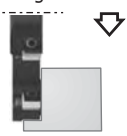
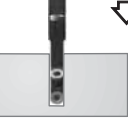
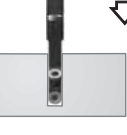
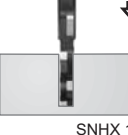
Slot cutters

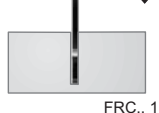
<p>1314.07 "T" Slots 90°</p>  <p>CC.. 0602.. CC.. 1204.. Page D.04</p>	<p>1314.30 "T" Slots 90°</p>  <p>CC.. 0602.. CC.. 1204.. Page D.05</p>	<p>08 3/4 0.95 Slot milling 90°</p>  <p>TP.. 1603.. TP.. 2204.. Page D.06</p>	<p>09 3/8 0.95 Slot milling 90°</p>  <p>SP.. 0903.. SP.. 1203.. SP.. 1504.. Page D.07</p>	<p>0940.96 Side milling 89°</p>  <p>SP.. 1203.. Page D.08</p>	<p>1520.90 Slot milling</p>  <p>RP.. 0802M0 Page D.09</p>
<p>1530.90 Slot milling</p>  <p>RP.. 1003M0 Page D.10</p>	<p>1549.90 Slot milling</p>  <p>RP.. 1204M0 Page D.11</p>	<p>1942.90 Slot milling 89°</p>  <p>SNHX 1102.. SNHX 1207.. Page D.12</p>	<p>2942.21 Circular miller</p>  <p>FRC.. 2,2 FRC.. 4,0 Page D.13</p>	<p>2942.90 Blade body</p>  <p>FRC.. 1,6 FRC.. 6,0 Page D.14</p>	

0 8	3 0	95	100	R
1	2	3	4	5
				6

1

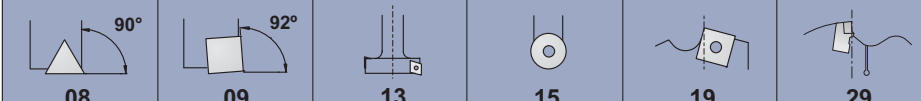



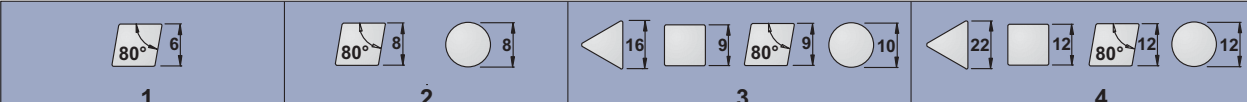

2

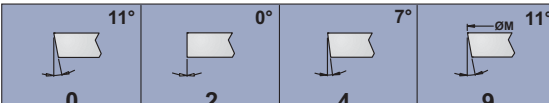

3



4

<p>07 Short Weldon</p>  <p>Ø12 Ø16 Ø20 Ø25 Ø32 Ø40</p>	<p>Short Morse DIN 228</p>  <p>M2-M3 30 M4 34 M5 35</p>	<p>90 Direct spindle mounting</p> 	<p>95 Direct spindle mounting</p> 	<p>96 Cutting hand</p> 
--	---	--	---	---

5

Diameter, mm.



6 *

Cutting hand



6 **

Cutting width



Inserts

Face milling cutters

Square shoulder cutters

Slot cutters



Characteristics:

T-Slot cutter with positive chip forming for all kind of materials.
 The insert is fixed by a Torx screw that allows a good chip evacuation and an easy use.
 Milling cutter equipped with short Weldon shank.

Applications:

The slot milling cutter works well on steels, alloyed steels, stainless steel, refractory casts and aluminium alloys.

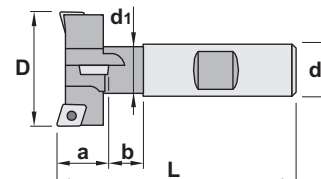
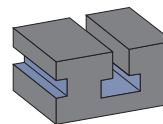
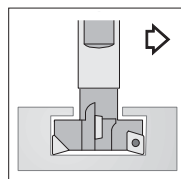

13¹4.07

Ref.			D	L	d	d1	a	b	Insert size	
1314.07.025.11	2+2	25	85	25	12	11	17	CC.. 0602..	0,250	
1324.07.032.14	2+2	32	95	25	15	14	22	CC.. 0803..	0,300	
1334.07.040.18	2+2	40	105	25	19	18	27	CC.. 09T3..	0,350	
1344.07.050.22	2+2	50	120	32	25	22	34	CC.. 1204..	0,700	



Ref.			
1314.07.025.11		1225	5507
1324.07.032.14		1230	5508
1334.07.040.18		1240	5515
1344.07.050.22		1250	5520

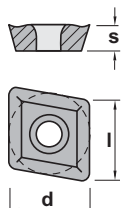

Ref.	CC..	l	s	d
CC.. 0602..		6,45	2,38	6,35
CC.. 0803..		8,05	3,18	7,94
CC.. 09T3..		9,65	3,97	9,52
CC.. 1204..		12,90	4,76	12,70

Positive 7° clearance - 80° rhombic inserts.

For more information see page: A.12

CCGT-AL	CCKT	CCMW			



Characteristics:

T-Slot cutter with positive chip forming for all kind of materials.
The insert is fixed by a Torx screw that allows a good chip evacuation and an easy use.
Milling cutter equipped with Morse shank.

Applications:

The slot milling cutter works well on steels, alloyed steels, stainless steel, refractory casts and aluminium alloys.

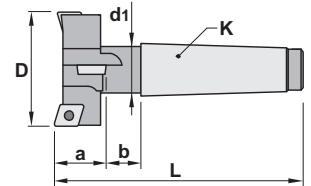
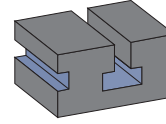
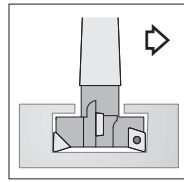

13 ¹ 44. ³⁰ _{44.34}			D	L	K	d1	a	b	Insert size	
Ref.	1314.30.025.11	2+2	25	125	MK3	12	11	17	CC.. 0602..	0,275
	1324.30.032.14	2+2	32	125	MK3	15	14	22	CC.. 0803..	0,300
	1334.30.040.18	2+2	40	134	MK3	19	18	27	CC.. 09T3..	0,350
	1344.34.050.22	2+2	50	165	MK4	25	22	34	CC.. 1204..	0,750

Ref.		
1314.30.025.11		1225
1324.30.032.14		1230
1334.30.040.18		1240
1344.34.050.22		1250

	CC..			Positive 7° clearance - 80° rhombic inserts.
	Ref.	l	s	
	CC.. 0602..	6,45	2,38	6,35
	CC.. 0803..	8,05	3,18	7,94
	CC.. 09T3..	9,65	3,97	9,52
	CC.. 1204..	12,90	4,76	12,70
	CCGT-AL	CCKT	CCMW	

For more information see page: A.12

Inserts

Face milling cutters

Square shoulder cutters

Slot cutters



Characteristics:

This economic slot cutter with an angle of 90° uses strong inserts allowing deep passes and high feed per teeth. Positive chip forming inserts are available to machine sticky materials.

The fixing system by wedge allows a good chip evacuation and an easy use.

Applications:

The slot milling cutter works well on steels, alloyed steels, stainless steel, refractory casts and aluminium alloys. Suitable for flat bottom applications.

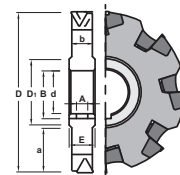
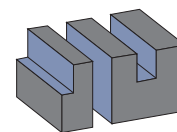
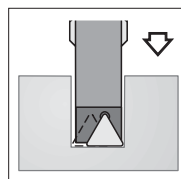

08³/₄ 0.95

Ref.			D	b	d	A	B	D1	E	a	Insert size	
0830.95.100.16	6	100	16	27	7	29,8	41	18	28	TP.. 1603..	0,650	
0830.95.125.16	8	125	16	32	8	34,8	48	18	39	TP.. 1603..	1,000	
0830.95.125.18	8	125	18	32	8	34,8	48	20	39	TP.. 1603..	1,150	
0830.95.125.20	8	125	20	32	8	34,8	48	22	39	TP.. 1603..	1,250	
0830.95.125.22	8	125	22	32	8	34,8	48	24	39	TP.. 1603..	1,400	
0830.95.160.16	10	160	16	40	10	43,5	58	18	49	TP.. 1603..	1,700	
0830.95.160.18	10	160	18	40	10	43,5	58	20	49	TP.. 1603..	1,950	
0830.95.160.20	10	160	20	40	10	43,5	58	22	49	TP.. 1603..	2,150	
0830.95.160.22	10	160	22	40	10	43,5	58	24	49	TP.. 1603..	2,350	
0830.95.200.16	12	200	16	50	12	53,8	72	18	60	TP.. 1603..	2,800	
0830.95.200.18	12	200	18	50	12	53,8	72	20	60	TP.. 1603..	3,100	
0830.95.200.20	12	200	20	50	12	53,8	72	22	60	TP.. 1603..	3,500	
0830.95.250.20	16	250	20	50	12	53,8	72	22	86	TP.. 1603..	5,900	
0830.95.315.24	20	315	24	50	12	53,8	84	26	114	TP.. 1603..	11,800	
0840.95.315.32	16	315	32	50	12	53,8	84	34	114	TP.. 2204..	16,000	
0840.95.400.32	20	400	32	50	12	53,8	84	34	150	TP.. 2204..	32,000	

Ref.									
0830.95.100.16	1088	1094	6010	6110	6562	6563	5004	5003	
0830.95.125.16	1088	1094	6010	6110	6562	6563	5004	5003	
0830.95.125.18	1088	1094	6010	6110	6562	6563	5004	5003	
0830.95.125.20	1088	1094	6010	6110	6562	6563	5004	5003	
0830.95.125.22	1088	1094	6010	6110	6562	6563	5004	5003	
0830.95.160.16	1088	1094	6010	6110	6562	6563	5004	5003	
0830.95.160.18	1088	1094	6010	6110	6562	6563	5004	5003	
0830.95.160.20	1088	1094	6010	6110	6562	6563	5004	5003	
0830.95.160.22	1088	1094	6010	6110	6562	6563	5004	5003	
0830.95.200.16	1088	1094	6010	6110	6562	6563	5004	5003	
0830.95.200.18	1088	1094	6010	6110	6562	6563	5004	5003	
0830.95.200.20	1088	1094	6010	6110	6562	6563	5004	5003	
0830.95.250.20	1088	1094	6010	6110	6562	6563	5004	5003	
0830.95.315.24	1088	1094	6010	6110	6562	6563	5004	5003	
0840.95.315.32	1088	1096	6011	6111	6564	6565	5004	5005	
0840.95.400.32	1088	1096	6011	6111	6564	6565	5004	5005	

		TP..	l	s	d	Positive 11° clearance - Triangular inserts.
Ref.	TP.. 1603..		16,50	3,18	9,52	
	TP.. 2204..		22,00	4,76	12,70	
For more information see page: A.21						
	TPKN	TPKR	TPUN	TPUX-R	TPUX-L	

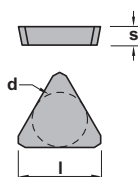



Characteristics:

This economic slot cutter with an angle of 92° uses strong inserts allowing deep passes and high feed per teeth. Positive chip forming inserts are available to machine sticky materials. The fixing system by wedge allows a good chip evacuation and an easy use.

Applications:

The slot milling cutter works well on steels, alloyed steels, stainless steel, refractory casts and aluminium alloys. Warning!! Not suitable for flat bottom applications.

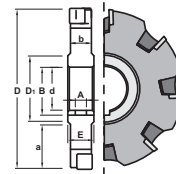
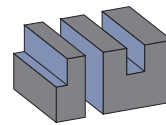
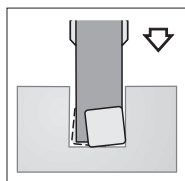

09³₅ 0.95

Ref.	D	b	d	A	B	D1	E	a	Insert size									kg	
									1156	1194	1504	6036	6037	5615	5509	5002	SP.. 0903..		
0930.95.050.10	6	50	10	16	4	18,0	28	12	10	1156	1194	1504	6036	6037	5615	5509	5002	SP.. 0903..	0,100
0930.95.063.10	6	63	10	22	6	24,5	35	12	12	1156	1194	1504	6036	6037	5615	5509	5002	SP.. 0903..	0,150
0930.95.080.10	8	80	10	22	6	24,5	35	12	20	1266	1194	1504	6013	6103	5615	5509	5002	SP.. 0903..	0,250
0930.95.100.10	10	100	10	27	7	29,8	41	12	28	1266	1194	1504	6013	6103	5615	5509	5002	SP.. 0903..	0,400
0930.95.100.12	10	100	12	27	7	29,8	41	14	28	1266	1294	1504	6013	6103	5615	5509	5002	SP.. 0903..	0,500
0930.95.100.14	10	100	14	27	7	29,8	41	16	28	1266	1294	1504	6013	6103	5615	5509	5002	SP.. 0903..	0,550
0930.95.125.10	12	125	10	32	8	34,8	48	12	39	1066	1194	1504	6013	6103	5615	5509	5002	SP.. 0903..	0,700
0930.95.125.12	12	125	12	32	8	34,8	48	14	39	1066	1294	1504	6013	6103	5615	5509	5002	SP.. 0903..	0,800
0930.95.125.14	12	125	14	32	8	34,8	48	16	39	1066	1294	1504	6013	6103	5615	5509	5002	SP.. 0903..	0,950
0930.95.160.10	14	160	10	40	10	43,5	58	12	49	1066	1194	1504	6013	6103	5615	5509	5002	SP.. 0903..	1,150
0930.95.160.12	14	160	12	40	10	43,5	58	14	49	1066	1294	1504	6013	6103	5615	5509	5002	SP.. 0903..	1,400
0930.95.160.14	14	160	14	40	10	43,5	58	16	49	1066	1294	1504	6013	6103	5615	5509	5002	SP.. 0903..	1,650
0940.95.080.16	6	80	16	22	6	24,5	35	18	20	1388	1295	1505	6010	6110	-	5004	5025	SP.. 1203..	0,400
0940.95.100.16	8	100	16	27	7	29,8	41	18	28	1088	1295	1505	6010	6110	-	5004	5025	SP.. 1203..	0,600
0940.95.125.16	10	125	16	32	8	34,8	48	18	39	1088	1295	1505	6010	6110	-	5004	5025	SP.. 1203..	1,050
0940.95.125.18	10	125	18	32	8	34,8	48	20	39	1088	1195	1505	6010	6110	-	5004	5025	SP.. 1203..	1,150
0940.95.125.20	10	125	20	32	8	34,8	48	22	39	1088	1195	1505	6010	6110	-	5004	5025	SP.. 1203..	1,350
0940.95.160.16	12	160	16	40	10	43,5	58	18	49	1088	1295	1505	6010	6110	-	5004	5025	SP.. 1203..	1,800
0940.95.160.18	12	160	18	40	10	43,5	58	20	49	1088	1195	1505	6010	6110	-	5004	5025	SP.. 1203..	1,950
0940.95.160.20	12	160	20	40	10	43,5	58	22	49	1088	1195	1505	6010	6110	-	5004	5025	SP.. 1203..	2,200
0940.95.200.16	16	200	16	50	12	53,8	72	18	60	1088	1295	1505	6010	6110	-	5004	5025	SP.. 1203..	2,850
0940.95.200.18	16	200	18	50	12	53,8	72	20	60	1088	1195	1505	6010	6110	-	5004	5025	SP.. 1203..	3,150
0940.95.200.20	16	200	20	50	12	53,8	72	22	60	1088	1195	1505	6010	6110	-	5004	5025	SP.. 1203..	3,550
0940.95.250.20	20	250	20	50	12	53,8	72	22	86	1088	1195	1505	6010	6110	-	5004	5025	SP.. 1203..	5,950
0940.95.250.24	20	250	24	50	12	53,8	72	26	86	1088	1195	1505	6010	6110	-	5004	5025	SP.. 1203..	7,250
0940.95.315.24	24	315	24	50	12	53,8	72	26	114	1088	1195	1505	6010	6110	-	5004	5025	SP.. 1203..	12,200
0950.95.315.30	20	315	30	50	12	53,8	72	32	114	1088	1196	1506	6011	6111	-	5004	5005	SP.. 1504..	15,500
0950.95.400.30	24	400	30	50	12	53,8	72	32	150	1088	1196	1506	6011	6111	-	5004	5005	SP.. 1504..	25,000

Slot cutters

Porcupine cutters

Specific applications and sets

Profile milling

Solid carbide

Drills

Boring heads

Arbors and adaptors

Ref.	SP..		l	s	d	Positive 11° clearance - Square inserts.
	SP.. 0903..		9,52	3,18	9,52	
SP.. 1203..		12,70	3,18	12,70		
SP.. 1504..		15,88	4,76	15,88		

SPKN	SPKR	SPUN			

For more information see page: A.19

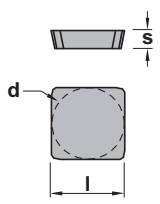

Inserts

Face milling cutters

Square shoulder cutters

Slot cutters



Characteristics:

This economic slot cutter with an angle of 92° uses strong inserts allowing deep passes and high feed per teeth. Positive chip forming inserts are available to machine sticky materials. The fixing system by wedge allows a good chip evacuation and an easy use.

Applications:

The slot milling cutter works well on steels, alloyed steels, stainless steel, refractory casts and aluminium alloys. Warning!! Not suitable for flat bottom applications.

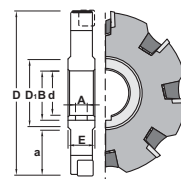
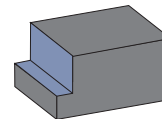
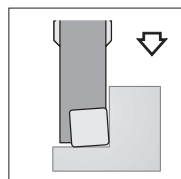

0940.96

Ref.			D	d	A	B	D ₁	E	a	Insert size	
0940.96.100.L	7	100	27	7	29,8	41	18	28	SP.. 1203..	0,650	
0940.96.100.R	7	100	27	7	29,8	41	18	28	SP.. 1203..	0,650	
0940.96.125.L	8	125	32	8	34,8	48	22	39	SP.. 1203..	1,350	
0940.96.125.R	8	125	32	8	34,8	48	22	39	SP.. 1203..	1,350	
0940.96.160.L	10	160	40	10	43,5	58	22	49	SP.. 1203..	2,350	
0940.96.160.R	10	160	40	10	43,5	58	22	49	SP.. 1203..	2,350	
0940.96.200.L	12	200	50	12	53,8	72	22	60	SP.. 1203..	3,800	
0940.96.200.R	12	200	50	12	53,8	72	22	60	SP.. 1203..	3,800	
0940.96.250.L	16	250	50	12	53,8	72	22	86	SP.. 1203..	6,200	
0940.96.250.R	16	250	50	12	53,8	72	22	86	SP.. 1203..	6,200	
0940.96.315.L	20	315	50	12	53,8	84	26	114	SP.. 1203..	12,250	
0940.96.315.R	20	315	50	12	53,8	84	26	114	SP.. 1203..	12,250	

Ref.							
0940.96.100.L	1088	1295	1505	-	6110	5004	5025
0940.96.100.R	1088	1295	1505	6010	-	5004	5025
0940.96.125.L	1088	1195	1505	-	6110	5004	5025
0940.96.125.R	1088	1195	1505	6010	-	5004	5025
0940.96.160.L	1088	1195	1505	-	6110	5004	5025
0940.96.160.R	1088	1195	1505	6010	-	5004	5025
0940.96.200.L	1088	1195	1505	-	6110	5004	5025
0940.96.200.R	1088	1195	1505	6010	-	5004	5025
0940.96.250.L	1088	1195	1505	-	6110	5004	5025
0940.96.250.R	1088	1195	1505	6010	-	5004	5025
0940.96.315.L	1088	1195	1505	-	6110	5004	5025
0940.96.315.R	1088	1195	1505	6010	-	5004	5025

		SP..	l	s	d	Positive 11° clearance - Square inserts.
Ref.	SP.. 1203..		12,70	3,18	12,70	
For more information see page: A.19						
	SPKN	SPKR	SPUN			



Characteristics:

This slot cutter uses round strong inserts allowing deep passes and high feed per teeth. Positive chip forming inserts are available to machine sticky materials.

The insert is fixed by a Torx screw that allows a good chip evacuation and an easy use.

Applications:

The slot milling cutter works well on steels, alloyed steels, stainless steel, refractory casts and aluminium alloys.

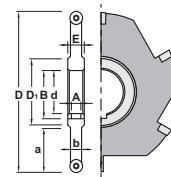
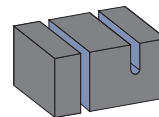
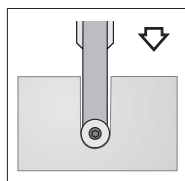

1520.90

Ref.		D	b	d	A	B	D1	E	a	Insert size	
1520.90.050	5	50	8	16	4	18,0	28	10	10	RPMW 0802M0	0,065
1520.90.063	6	63	8	22	6	24,5	35	10	12	RPMW 0802M0	0,100
1520.90.080	7	80	8	22	6	24,5	35	10	20	RPMW 0802M0	0,200
1520.90.100	8	100	8	27	7	29,8	41	10	28	RPMW 0802M0	0,300
1520.90.125	9	125	8	32	8	34,8	48	10	39	RPMW 0802M0	0,550
1520.90.160	10	160	8	40	10	43,5	58	10	49	RPMW 0802M0	0,850
1520.90.200	12	200	8	50	12	53,8	72	10	60	RPMW 0802M0	1,450

Ref.		
1520.90.050	1230	5608
1520.90.063	1230	5608
1520.90.080	1230	5608
1520.90.100	1230	5608
1520.90.125	1230	5608
1520.90.160	1230	5608
1520.90.200	1230	5608

RPMW		l	s	d	Positive 11° clearance - Round inserts.
Ref.	RPMW 0802M0	-	2,38	8,00	
For more information see page: A.15					
	RPMW				

Slot cutters
Porcupine cutters
Specific applications and sets
Profile milling
Solid carbide
Drills
Boring heads
Arbors and adaptors

Inserts

Face milling cutters

Square shoulder cutters

Slot cutters



Characteristics:

This slot cutter uses round strong inserts allowing deep passes and high feed per teeth. Positive chip forming inserts are available to machine sticky materials.

The insert is fixed by a Torx screw that allows a good chip evacuation and an easy use.

Applications:

The slot milling cutter works well on steels, alloyed steels, stainless steel, refractory casts and aluminium alloys.

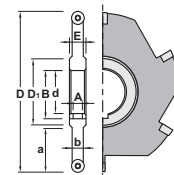
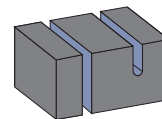
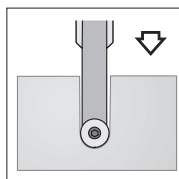

1530.90

Ref.			D	b	d	A	B	D1	E	a	Insert size	
1530.90.050	5	50	10	16	4	18,0	28	12	10	RPMW 1003M0	0,060	
1530.90.063	5	63	10	22	6	24,5	35	12	12	RPMW 1003M0	0,100	
1530.90.080	6	80	10	22	6	24,5	35	12	20	RPMW 1003M0	0,150	
1530.90.100	7	100	10	27	7	29,8	41	12	28	RPMW 1003M0	0,350	
1530.90.125	8	125	10	32	8	34,8	48	12	39	RPMW 1003M0	0,650	
1530.90.160	9	160	10	40	10	43,5	58	12	49	RPMW 1003M0	1,100	
1530.90.200	10	200	10	50	12	53,8	72	12	60	RPMW 1003M0	1,750	
1530.90.250	12	250	10	50	12	53,8	72	12	86	RPMW 1003M0	2,800	

Ref.		
1530.90.050	1440	5615
1530.90.063	1240	5615
1530.90.080	1240	5615
1530.90.100	1240	5615
1530.90.125	1240	5615
1530.90.160	1240	5615
1530.90.200	1240	5615
1530.90.250	1240	5615

RPMW		l	s	d	Positive 11° clearance - Round inserts.
Ref.	RPMW 1003M0	-	3,18	10,00	
For more information see page: A.15					
RPMW					

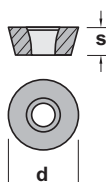



Characteristics:

This slot cutter uses round strong inserts allowing deep passes and high feed per teeth. Positive chip forming inserts are available to machine sticky materials.

The insert is fixed by a Torx screw that allows a good chip evacuation and an easy use.

Applications:

The slot milling cutter works well on steels, alloyed steels, stainless steel, refractory casts and aluminium alloys.

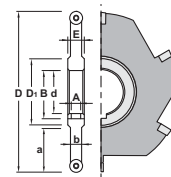
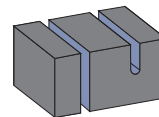
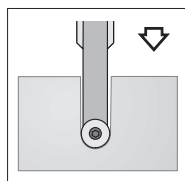

1549.90

Ref.		D	b	d	A	B	D1	E	a	Insert size	
1549.90.080	6	80	12	22	6	24,5	35	14	20	RPMW 1204M0	0,250
1549.90.100	7	100	12	27	7	29,8	41	14	28	RPMW 1204M0	0,400
1549.90.125	8	125	12	32	8	34,8	48	14	39	RPMW 1204M0	0,750
1549.90.160	9	160	12	40	10	43,5	58	14	49	RPMW 1204M0	1,200
1549.90.200	10	200	12	50	12	53,8	72	14	60	RPMW 1204M0	1,900
1549.90.250	12	250	12	50	12	53,8	72	14	86	RPMW 1204M0	3,250

Ref.		
1549.90.080	1240	5615
1549.90.100	1240	5615
1549.90.125	1240	5615
1549.90.160	1240	5615
1549.90.200	1240	5615
1549.90.250	1240	5615

RPMW		l	s	d	Positive 11° clearance - Round inserts.
Ref.	RPMW 1204M0	-	4,76	12,00	
For more information see page: A.15					
RPMW					

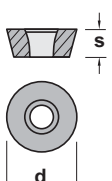

Slot cutters
Porcupine cutters
Specific applications and sets
Profile milling
Solid carbide
Drills
Boring heads
Arbors and adaptors

Inserts

Face milling cutters

Square shoulder cutters

Slot cutters



Characteristics:

This slot cutter with an angle of 92° uses strong inserts allowing deep passes and high feed per teeth. Positive chip forming inserts are available to machine sticky materials.

The insert is fixed by a Torx screw that allows a good chip evacuation and an easy use.

Applications:

The slot milling cutter works well on steels, alloyed steels, stainless steel, refractory casts and aluminium alloys. Warning!! Not suitable for flat bottom applications.

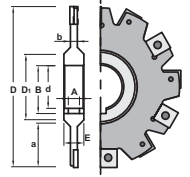
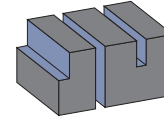
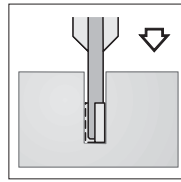

1942.90

Ref.			D	b	d	A	B	D1	E	a			Insert size	
1942.90.100.04	12	100	4	27	7	29,8	41	12	25	1735	5607	SNHX 1102..	0,200	
1942.90.125.04	14	125	4	32	8	34,8	48	12	40	1735	5607	SNHX 1102..	0,350	
1942.90.100.05	12	100	5	27	7	29,8	41	12	25	1835	5607	SNHX 1103..	0,250	
1942.90.125.05	14	125	5	32	8	34,8	48	12	40	1835	5607	SNHX 1103..	0,400	
1942.90.160.05	18	160	5	40	10	43,5	58	12	44	1835	5607	SNHX 1103..	0,650	
1942.90.100.06	10	100	6	27	7	29,8	41	12	25	1745	5615	SNHX 1203..	0,300	
1942.90.125.06	12	125	6	32	8	34,8	48	12	40	1745	5615	SNHX 1203..	0,450	
1942.90.160.06	16	160	6	40	10	43,5	58	12	44	1745	5615	SNHX 1203..	0,750	
1942.90.200.06	18	200	6	50	12	53,8	72	12	54	1745	5615	SNHX 1203..	1,150	
1942.90.250.06	24	250	6	50	12	53,8	72	12	79	1745	5615	SNHX 1203..	1,800	
1942.90.100.08	10	100	8	27	7	29,8	41	12	25	1846	5615	SNHX 12045..	0,350	
1942.90.125.08	12	125	8	32	8	34,8	48	12	40	1846	5615	SNHX 12045..	0,550	
1942.90.160.08	16	160	8	40	10	43,5	58	12	44	1846	5615	SNHX 12045..	0,950	
1942.90.200.08	18	200	8	50	12	53,8	72	12	54	1846	5615	SNHX 12045..	1,550	
1942.90.250.08	24	250	8	50	12	53,8	72	12	79	1846	5615	SNHX 12045..	2,400	
1942.90.100.10	10	100	10	27	7	29,8	41	12	25	1845	5615	SNHX 1205..	0,400	
1942.90.125.10	12	125	10	32	8	34,8	48	12	40	1845	5615	SNHX 1205..	0,700	
1942.90.160.10	16	160	10	40	10	43,5	58	12	44	1845	5615	SNHX 1205..	1,150	
1942.90.200.10	18	200	10	50	12	53,8	72	12	54	1845	5615	SNHX 1205..	1,900	
1942.90.250.10	24	250	10	50	12	53,8	72	12	79	1845	5615	SNHX 1205..	3,050	
1942.90.100.12	10	100	12	27	7	29,8	41	16	25	1847	5615	SNHX 1207..	0,500	
1942.90.125.12	12	125	12	32	8	34,8	48	16	40	1847	5615	SNHX 1207..	0,850	
1942.90.160.12	16	160	12	40	10	43,5	58	16	44	1847	5615	SNHX 1207..	1,400	
1942.90.200.12	18	200	12	50	12	53,8	72	16	54	1847	5615	SNHX 1207..	2,350	
1942.90.250.12	24	250	12	50	12	53,8	72	16	79	1847	5615	SNHX 1207..	3,750	

Ref.	SNHX			Negative square inserts.
	l	s	d	
SNHX 1102..	11,00	2,38	11,00	
SNHX 1103..	11,00	2,70	11,00	
SNHX 1203..	12,70	3,18	12,70	
SNHX 12045..	12,70	4,50	12,70	
SNHX 1205..	12,70	5,40	12,70	
SNHX 1207..	12,70	7,00	12,70	

For more information see page: A.18

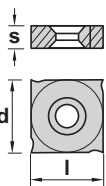



Characteristics:

Circular miller.
 Self-clamping tool with double prism and fixed reference point.
 The special shape of the chip groove in the insert slot allows a continuous chip flow.
 Each insert cuts over the full cutting edge so that compared to staggered or alternate tooth cutters (pre-finishing cutters) the feed per tool revolution can be doubled.
 Inserts can be changed in less than 10 seconds per insert without removing the cutter from the machine.
 The inserts are released from the prism with the help of the included assembly-key.

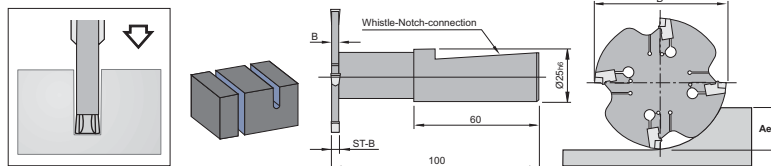

2942.21			ST-B	B	D	Ae	Rev max		Insert size	
Ref.	2942.21.0631.8	4	2,2	1,8	63	20	1250	5733	FRC.. 2,2	0,370
	2942.21.0632.4	4	3,0	2,4	63	20	1250	5733	FRC.. 3,0	0,385
	2942.21.0633.0	4	4,0	3,0	63	20	1250	5733	FRC.. 4,0	0,400
	2942.21.0801.8	5	2,2	1,8	80	26	1000	5733	FRC.. 2,2	0,405
	2942.21.0802.4	5	3,0	2,4	80	26	1000	5733	FRC.. 3,0	0,430
	2942.21.0803.0	5	4,0	3,0	80	26	1000	5733	FRC.. 4,0	0,460
	2942.21.1001.8	8	2,2	1,8	100	36	800	5733	FRC.. 2,2	0,445
	2942.21.1002.4	8	3,0	2,4	100	36	800	5733	FRC.. 3,0	0,480
	2942.21.1003.0	8	4,0	3,0	100	36	800	5733	FRC.. 4,0	0,520

Slot cutters

Porcupine cutters

Specific applications and sets

Profile milling

Solid carbide

Drills

Boring heads

Arbors and adaptors

Ref.	FRC..		s	r	Single-ended inserts
	FRC 2,2		2,2	0,20	
FRC 3,0		3,0	0,20		
FRC 4,0		4,0	0,20		
FRCR 3,0		3,0	1,50		
FRCR 4,0		4,0	2,00		

For more information see page: A.13

FRC	FRCR					

Inserts

Face milling cutters

Square shoulder cutters

Slot cutters



Characteristics:

Side Milling cutter Blade Body.

Self-clamping tool with double prism and fixed reference point.

The special shape of the chip groove in the insert slot allows a continuous chip flow.

Each insert cuts over the full cutting edge so that compared to staggered or alternate tooth cutters (pre-finishing cutters) the feed per tool revolution can be doubled.

Inserts can be changed in less than 10 seconds per insert without removing the cutter from the machine.

The inserts are released from the prism with the help of the included assembly-key.

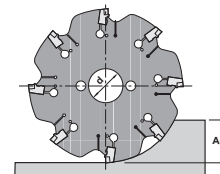
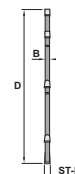
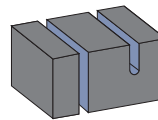
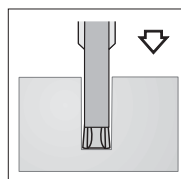

2942.90

Ref.	Number of inserts	ST-B	B	D	d	Ae	Rev max. min-1	Surface finish	Insert size	Weight (Kg)
2942.90.0801.2	4	1.6	1.2	80	16	22	1000	5733	FRC.. 1,6	0,045
2942.90.0801.8	4	2.2	1.8	80	16	22	1000	5733	FRC.. 2,2	0,070
2942.90.0802.4	4	3.0	2.4	80	16	22	1000	5733	FRC.. 3,0	0,090
2942.90.0803.0	4	4.0	3.0	80	16	22	1000	5733	FRC.. 4,0	0,115
2942.90.0804.4	4	5.0+6.0	4.4	80	16	22	1000	5733	FRC.. 5,0-6,0	0,165
2942.90.1001.2	8	1.6	1.2	100	22	28	800	5733	FRC.. 1,6	0,070
2942.90.1001.8	8	2.2	1.8	100	22	28	800	5733	FRC.. 2,2	0,105
2942.90.1002.4	8	3.0	2.4	100	22	28	800	5733	FRC.. 3,0	0,130
2942.90.1003.0	8	4.0	3.0	100	22	28	800	5733	FRC.. 4,0	0,175
2942.90.1004.4	8	5.0+6.0	4.4	100	22	28	800	5733	FRC.. 5,0-6,0	0,260
2942.90.1251.2	10	1.6	1.2	125	22	40	650	5733	FRC.. 1,6	0,110
2942.90.1251.8	10	2.2	1.8	125	22	40	650	5733	FRC.. 2,2	0,170
2942.90.1252.4	10	3.0	2.4	125	22	40	650	5733	FRC.. 3,0	0,220
2942.90.1253.0	10	4.0	3.0	125	22	40	650	5733	FRC.. 4,0	0,280
2942.90.1254.4	10	5.0+6.0	4.4	125	22	40	650	5733	FRC.. 5,0-6,0	0,410
2942.90.1602.4	15	3.0	2.4	160	32	49	500	5733	FRC.. 3,0	0,360
2942.90.1603.0	15	4.0	3.0	160	32	49	500	5733	FRC.. 4,0	0,450
2942.90.1604.4	15	5.0+6.0	4.4	160	32	49	500	5733	FRC.. 5,0-6,0	0,660
2942.90.2002.4	20	3.0	2.4	200	40	63	400	5733	FRC.. 3,0	0,570
2942.90.2003.0	20	4.0	3.0	200	40	63	400	5733	FRC.. 4,0	0,700
2942.90.2004.4	20	5.0+6.0	4.4	200	40	63	400	5733	FRC.. 5,0-6,0	1,040
2942.90.2502.4	24	3.0	2.4	250	40	88	300	5733	FRC.. 3,0	0,900
2942.90.2503.0	24	4.0	3.0	250	40	88	300	5733	FRC.. 4,0	1,125
2942.90.2504.4	24	5.0+6.0	4.4	250	40	88	300	5733	FRC.. 5,0-6,0	1,650

Ref.	FRC..		Single-ended inserts	
	s	r		
FRC 1,6	1,6	0,15		
FRC 2,2	2,2	0,20		
FRC 3,0	3,0	0,20		
FRC 4,0	4,0	0,20		
FRC 5,0	5,0	0,30		
FRC 6,0	6,0	0,30		
FRCR 3,0	3,0	1,50		
FRCR 4,0	4,0	2,00		
FRCR 5,0	5,0	2,50		
FRCR 6,0	6,0	3,00		
	FRC	FRCR		

For more information see page: A.13

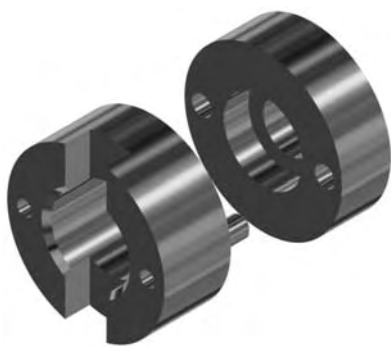

Characteristics:
Drive-rings (set) with cross groove.
Applications:
For 2942.90 milling cutters.

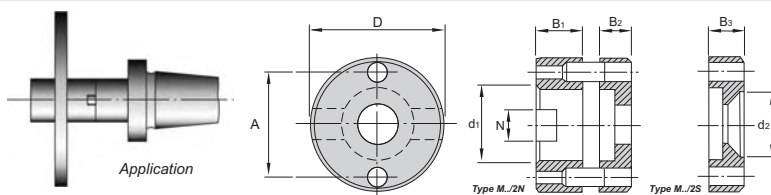

M		D	d1	d2	A	B1	B2	B3	N	For side milling cutter	Kg
Ref.	M 16/2 N	32	16	10	25	13,5	10	-	8,4	80	0,130
	M 22/2 N	40	22	12	32	14,5	10	-	10,4	100-125	0,200
	M 32/2 N	58	32	18	46	17,5	15	-	14,4	160	0,590
	M 40/2 N	70	40	22	56	19,5	17	-	16,4	200-250	0,820
	M 16/2 S	32	16	10	25	13,5	-	10	8,4	80	0,125
	M 22/2 S	40	22	12	32	14,5	-	10	10,4	100-125	0,190
	M 32/2 S	58	32	18	46	17,5	-	15	14,4	160	0,570
	M 40/2 S	70	40	22	56	19,5	-	17	16,4	200-250	0,800

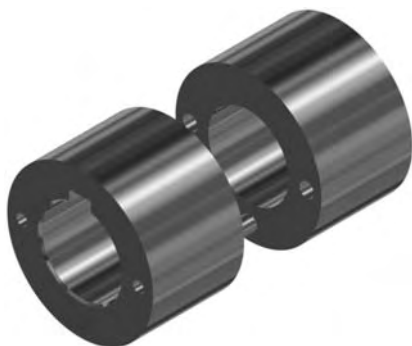

Characteristics:
Drive-rings (set) with longitudinal groove.
Applications:
For 2942.90 milling cutters.

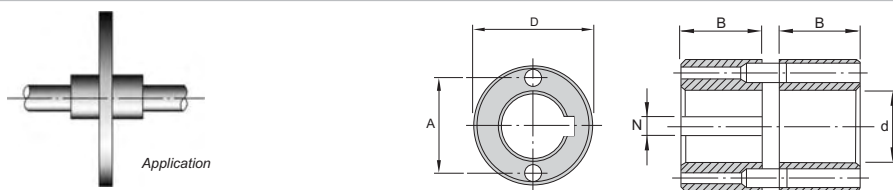

MN		D	d	A	B	N	For side milling cutter	Kg
Ref.	MN 16/2	32	16	25	25	4	80	0,240
	MN 22/2	40	22	32	25	6	100-125	0,340
	MN 32/2	58	32	46	25	8	160	0,720
	MN 40/2	70	40	56	25	10	200-250	1,010

Inserts

Face milling cutters

Square shoulder cutters

Slot cutters

Cutting data for slot side and face milling cutters

Cutting speed nominal values

Material	P	HB	Basic qualities			
			TIN25	PM25	KM15	TL40
			Cutting speed m/min.			
Unalloyed steel		90-250	100-210	80-180		
Low alloyed steel		130-400	50-150	50-140		
High alloyed steel		150-500	30-90	40-90		
Martensitic, stainless steel ferritic		150-270	100-200	80-130		40-80
Steel castings		150-200	60-130	40-90		

Material	M	HB	Basic qualities			
			TIN25	PM25	KM15	TL40
			Cutting speed m/min.			
Austenitic, stainless steel		150-270	80-180	50-120		20-50
Titanium		300-450			20-80	

Material	K	HB	Basic qualities			
			TIN25	PM25	KM15	TL40
			Cutting speed m/min.			
Malleable cast iron		110-230			60-90	
Grey cast iron		180-260			80-120	
Nodular cast iron		160-250			60-80	
Aluminium alloys					200-600	
Bronze and brass alloys		60-150			70-150	

Machining example

Working piece

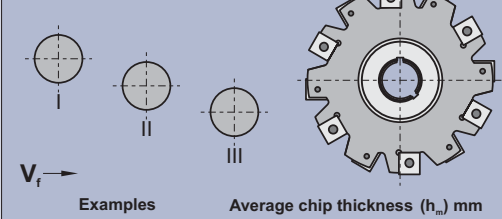

- I 0,08 - 0,09
- II 0,08
- III 0,07 - 0,08

Example I: $f_z \sim h_m$ Example III: $f_z = h_m \sqrt{\frac{D}{a_e}}$

Example II: f_z must be calculated between examples I and II

f_z = Feed per tooth
 D = Milling cutter diameter
 a_e = Radial cutting depth
 h_m = Average chip thickness

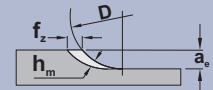

Feed nominal values

Depending on the milling cutter situation and in relationship with its diameter and the cutting depth, the average chip thickness (h_m) can considerably vary, but it will always be smaller than the feed per tooth.

When you mill a groove, the feed is distributed between two stepped inserts, which are symmetrically spaced one at each side of the milling cutter, forming together the slot. Therefore, when you use the formulae, the z value (number of teeth) must always be divided by two.

Cutting data for slot side and face milling cutters

Cutting speed nominal values - h_m 0,05-0,12

Material	P	HB	TIN25	PM25	TL40
			Cutting speed m/min.		
			Unalloyed steel	110-310	140-240
Low alloyed steel		125-450	130-210	85-180	45-80
High alloyed steel		150-500	120-80	60-120	30-65
Stainless		150-270			40-90
Steel castings		150-250	130-210	55-115	25-60

Material	M	HB	TL40	KM15
			Cutting speed m/min.	
			Austenitic, stainless steel	40-90
Titanium		20-80		

Material	K	HB	KM15	PM25
			Cutting speed m/min.	
			Malleable cast iron	110-230
Grey cast iron		180-260	80-120	60-120
Nodular cast iron-S. graphite		160-250	60-80	40-80
Aluminium alloys		30-100	200-600	
Bronze and brass alloys		60-150	70-150	

Feed nominal values

The chip average Thickness (h_m) must be 0,10mm.

This corresponds to a feed per tooth of 0,3mm in most of the operations made by a side and face milling cutter.

If the radial cutting depth (a_e) is too small compared with the milling cutter diameter, use the following formula:

NOTE: In order to calculate the table feeds, use the halfth of the inserts in a three cut milling cutter and a face milling cutter in order to get the effective number of teeth.

Table feed = rpm x number of effective teeth x f_z

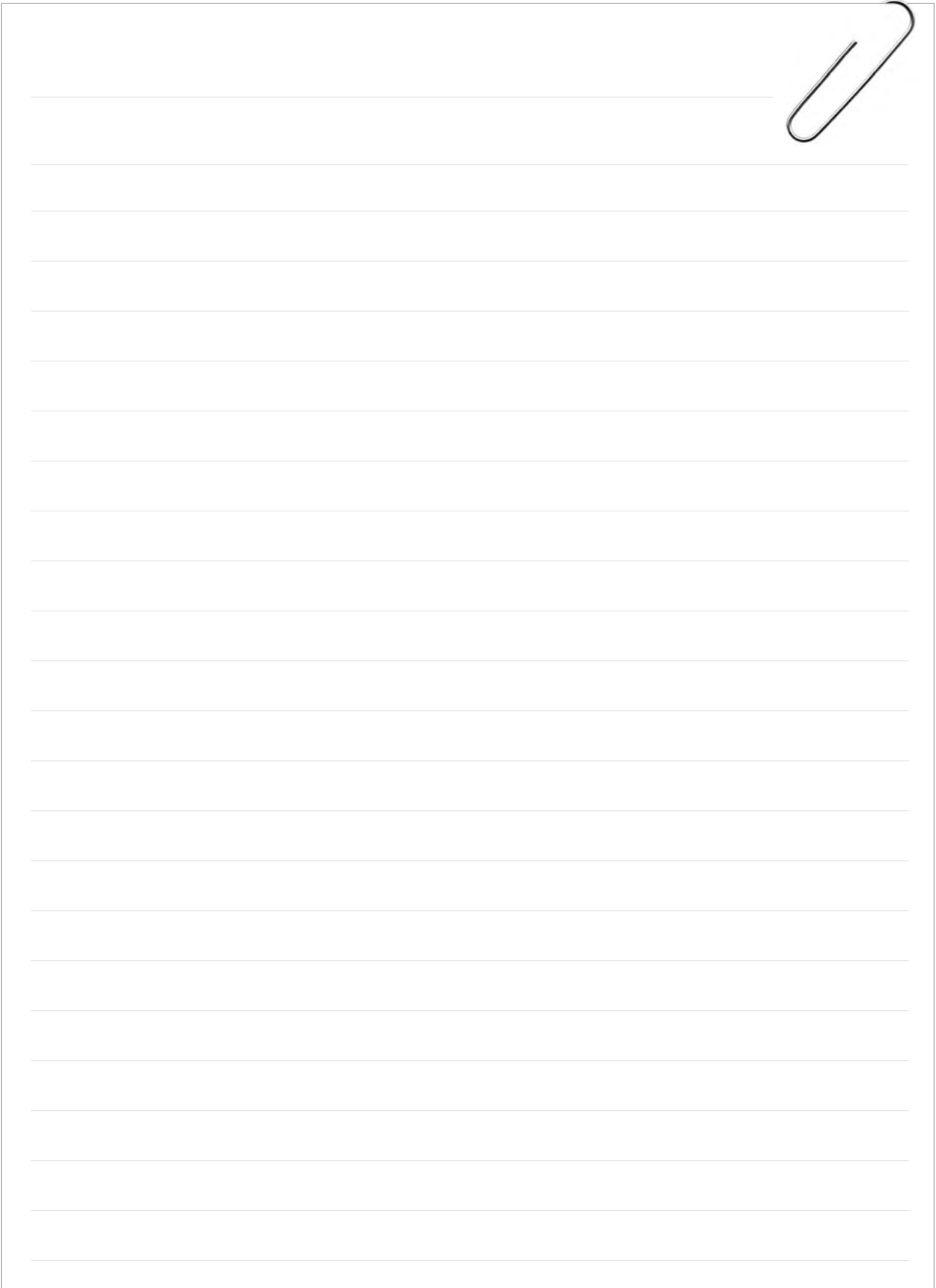

A large rectangular area with horizontal lines for writing, resembling a notepad. A paperclip is attached to the top right corner.

Slot cutters

Porcupine cutters

Specific applications and sets

Profile milling

Solid carbide

Drills

Boring heads

Arbors and adaptors