

BAS-V 125 - 200 -250 - 320







Tavole girevoli cnc con inclinazione manuale Cnc Rotary tables with manual tilting

Posizionamento asse inclinabile con volantino
Trasmissione meccanica
Bloccaggio pneumatico asse girevole
Bloccaggio meccanico manuale asse inclinabile

Tilting axis positioning by handwheel
Mechanical transmission
Rotary axis pneumatic clamping
Tilting axis manual mechanical clamping



Caratteristiche - Modelli Specifications - Models		BAS-V 125		BAS-V 200		BAS-V 250		BAS-V 320	
Diametro tavola Table diameter	mm.	125		198		248		318	
Diametro foro centrale Center bore	mm.	28		42		72		81	
Altezza punta Center height	mm.	127		151		180		235	
Larghezza cave a T Table T-slots width	mm.	6		9,7		11,7		13,7	
Inclinazione Tilt range		-15° ÷ 110°		-10° ÷ 110°		-10° ÷ 100°		-10° ÷ 100°	
Asse Axis		Girevole Rotary	Inclinabile Tilting	Girevole Rotary	Inclinabile Tilting	Girevole Rotary	Inclinabile Tilting	Girevole Rotary	Inclinabile Tilting
Sistema di bloccaggio Clamp system		Pneumatico Pneumatic	Manuale Manual	Pneumatico Pneumatic	Manuale Manual	Pneumatico Pneumatic	Manuale Manual	Pneumatico Pneumatic	Manuale Manual
Capacità di bloccaggio Clamp torque	Nm.	250	600	400	800	600	1000	1000	1500
Rapporto vite/corona Worm screw/wheel ratio		1/180	---	1/180	---	1/180	---	1/180	---
Grandezza motore (pagina 43) Servo motor size (page 43)		1	---	2	---	3	---	4	---
Velocità massima di rotazione Max rotation speed	Rpm	16,6	---	16,6	---	16,6	---	16,6	---
Precisione di posizionamento Indexing accuracy	sec.	± 15	± 30	± 15	± 30	± 15	± 30	± 15	± 30
Incremento minimo Minimum increase		0,001°		0,001°		0,001°		0,001°	
Peso max ammesso 0° Max allowable load 0°	 Kg.	45		85		130		220	
Peso max ammesso 90° Max allowable load 90°	 Kg.	25		45		90		140	
Spinta max ammessa 0° Max allowable thrust 0°	 N.	4600		6200		10300		13100	
Spinta max ammessa 90° Max allowable thrust 90°	 FxL Nm	160		350		650		830	
Coppia di lavoro Working torque	 Nm	124		194		254		630	
Peso netto tavola Table net weight	Kg.	56		88		125		278	

Tavole girevoli cnc con inclinazione manuale
Cnc Rotary tables with manual tilting

BAS-V 125

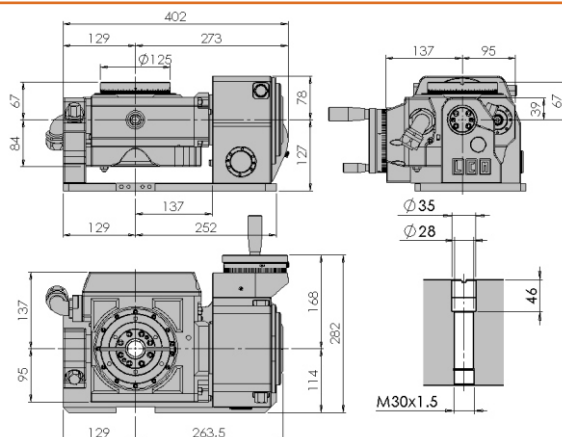
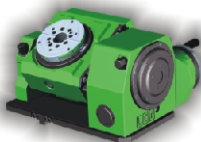

BAS-V 200

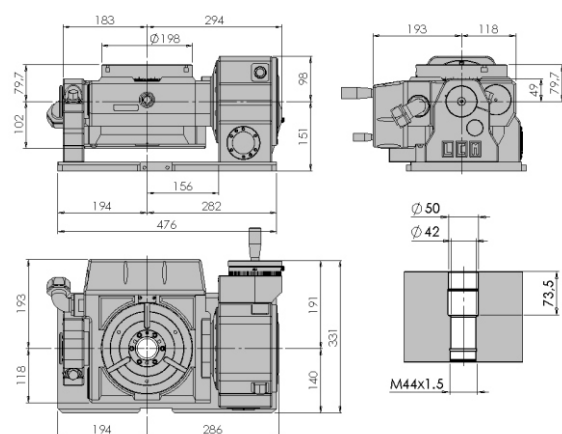
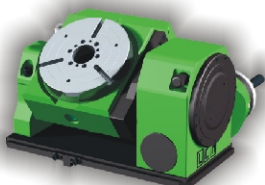

BAS-V 250

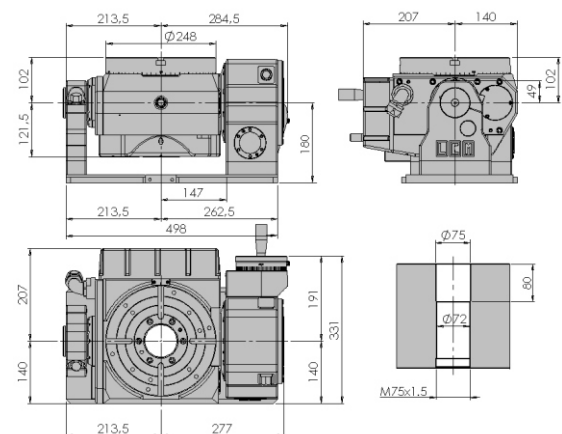
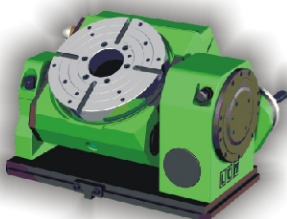

BAS-V 320

