





## Tavole girevoli cnc Cnc Rotary tables

Posizionamento asse verticale-orizzontale  
Trasmissione meccanica  
Bloccaggio pneumatico

Vertical-horizontal positioning  
Mechanical transmission  
Pneumatic clamping



Caratteristiche - Modelli Specifications - Models		TDE 125	TDE 200	TDE 250	TDE 350
Diametro tavola Table diameter	mm.	125	198	248	348 (398 Opt.)
Diametro foro centrale Center bore	mm.	28	42	81	101
Altezza punta Center height	mm.	110	151	180	225
Larghezza cave a T Table T-slots width	mm.	6	9,7	11,7	13,7
Sistema di bloccaggio Clamp system		Pneumatico Pneumatic	Pneumatico Pneumatic	Pneumatico Pneumatic	Pneumatico Pneumatic
Capacità di bloccaggio Clamp torque	Nm.	250	400	620	1000
Rapporto vite/corona Worm screw/wheel ratio		1/90	1/90	1/60	1/60
Rapporto vite/motore Worm screw/motor ratio		1/2	1/2	1/2	1/2
Grandezza motore (pagina 43) Servo motor size (page 43)		1	2	3	4
Velocità massima di rotazione Max rotation speed	Rpm	16,6	16,6	25	25
Precisione di posizionamento Indexing accuracy	sec.	±15	±15	±15	±15
Incremento minimo Minimum increase		0,001°	0,001°	0,001°	0,001°
Peso max ammesso verticale Max allowable load vertical	 Kg.	80	100	270	800
Peso max ammesso orizzontale Max allowable load horizontal	 Kg.	150	195	560	1000
Spinta max ammessa verticale Max allowable thrust vertical	 FxL Nm	300	950	1700	2200
Spinta max ammessa orizzontale Max allowable thrust horizontal	 N.	6000	12000	23000	38000
Coppia di lavoro Working torque	 Nm	124	194	336	670
Peso netto tavola Table net weight	Kg.	30	57	98	230

**TDE 125**

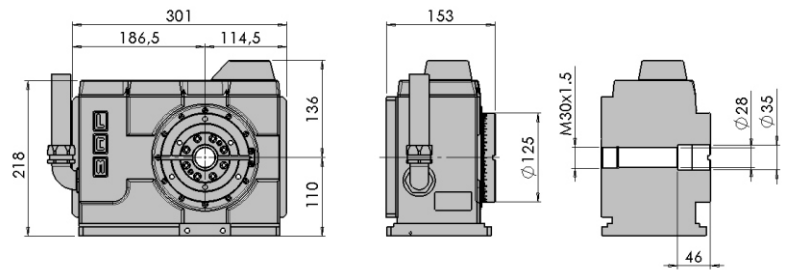
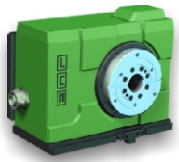

**TDE 200**

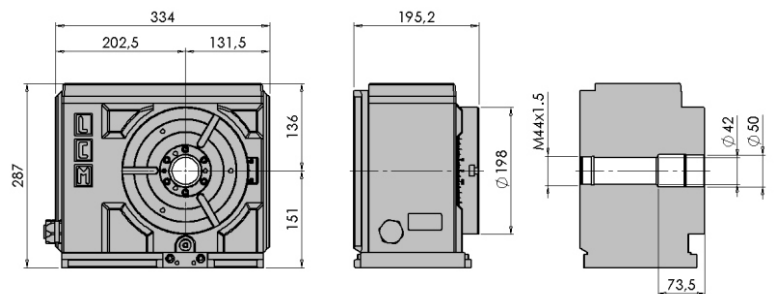
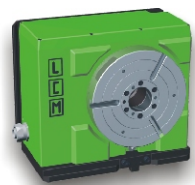

**TDE 250**

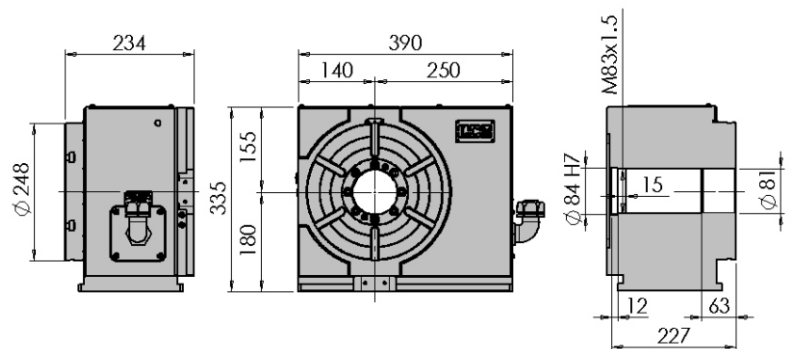
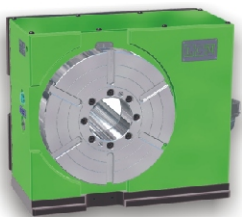

**TDE 350**

